

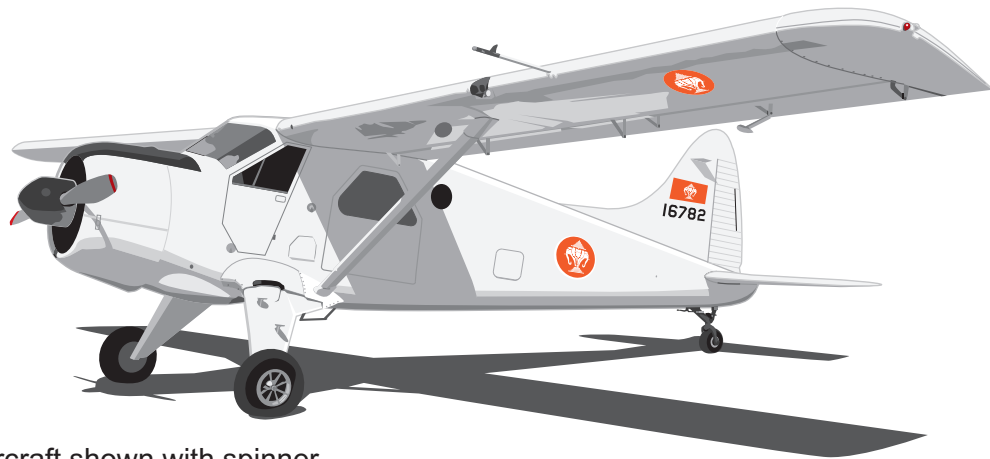

Royal Lao Air Force DHC Beaver 1958

Number 16782 represents a small number of Beavers supplied to Laos in the late 1950s. They ideally suited to the short, unprepared strips within the country. One aircraft was believed to have had a .50 Cal M.G mounted as a rudimentary gunship.



Aircraft shown with spinner

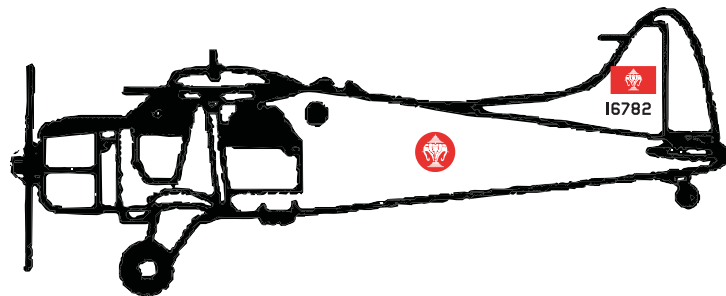

It is likely the aircraft flew for much of its time without a spinner.

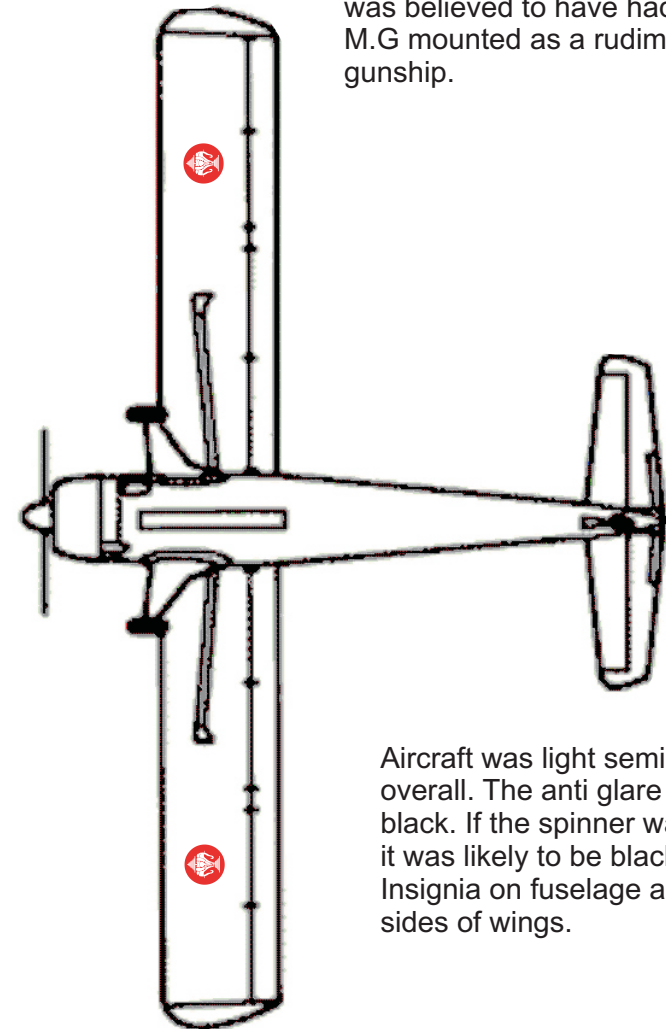

Aircraft was light semi gloss grey overall. The anti glare panel is black. If the spinner was fitted it was likely to be black or grey. Insignia on fuselage and both sides of wings.